

**ACCESS DOORS**

FIRE EXTINGUISHER CABINETS  
FIRE EXTINGUISHER & VALVE COMBINATION CABINETS  
VALVE CABINETS  
FIRE HOSE CABINETS  
INDUSTRIAL OUTDOOR FIRE EQUIPMENT STORAGE  
FLAMMABLE SAFETY STORAGE CABINETS  
FIRE SAFETY PLAN BOXES  
FIRE HOSE RACKS & TRAYS



**THE WILLIAMS**  
**BROTHERS**  
CORPORATION



# PREMIUM ACCESS DOORS

# WILLIAMS BROTHERS, YOUR ORIGINAL AND TRUSTED SOURCE OF QUALITY ACCESS DOORS AND FIRE EQUIPMENT

For four generations, the Williams family has been serving the ever-changing needs of the construction and fire equipment industries with a total commitment to customer satisfaction. As a family owned and operated business, with manufacturing facilities in North America, we are dedicated to designing and fabricating reliable, high quality products for the global market.

## WE OPERATE AS TWO BUSINESS DIVISIONS:

**Williams Brothers Corporation** manufactures a broad range of access doors and fire equipment storage, including fire extinguisher and valve cabinets.



THE WILLIAMS  
**BROTHERS**  
CORPORATION



**STRIKE FIRST**  
CORPORATION

**Strike First Corporation** is a leading manufacturer and supplier of portable fire extinguishers, accessories, and brackets that are UL/ULC Listed and USCG approved.

[strike-first.com](http://strike-first.com)

WILLIAMS BROTHERS STANDARDS MET



[info@williams-brothers.com](mailto:info@williams-brothers.com)  
[williams-brothers.com](http://williams-brothers.com)

# WILLIAMS BROTHERS THE FINEST IN STANDARD AND CUSTOM METALWORK



At our Scarborough, Ontario, facility, we design and manufacture robust, durable and attractive access doors, metalwork and cabinets for the construction and fire protection industries.

For indoor and outdoor use, for industrial, commercial or residential applications – in a broad selection of colours and finishes – we make it all. Choose from a broad selection of standard units or bring us your custom plans. Our in-house engineering and design team can meet your most complex demands. Our service always includes on-time delivery for customers worldwide.

Contact us directly at [info@williams-brothers.com](mailto:info@williams-brothers.com) to learn more.

# STRIKE FIRST PORTABLE FIRE EXTINGUISHERS OF UNCOMPROMISED QUALITY



Customers who demand the highest standards in fire protection choose Strike First. Designed and manufactured in North America, our fire extinguishers are constructed for reliable, long lasting service – and are backed by solid customer service and warranties up to six years.

Our extinguishers are built tough with a reputation of easy serviceability for commercial, industrial, institutional and residential applications.

**When seconds count, STRIKE FIRST.**

Contact us directly at [info@strike-first.com](mailto:info@strike-first.com) to learn more.

## CONTENTS

History and Index .....	1
<b>GENERAL PURPOSE ACCESS DOORS</b>	
WB-GP Premium .....	2
WB-UAD Utility .....	3
WB-Basic .....	4
WB-NT No Trim .....	4
WB-RP Removable Panel .....	5
WB-SMP Surface Mounted Panel .....	5
WB-AL Aluminum Insulated .....	6
WB-ALU Aluminum Uninsulated .....	6
<b>FIRE RATED ACCESS DOORS</b>	
WB-FR Standard Fire Rated .....	7
WB-FR Standard Ultra Fire Rated .....	7
WB-FR Basic Uninsulated .....	8
WB-FR Standard Drywall .....	9
WB-FR Standard Plaster .....	9
<b>DRYWALL/PLASTER ACCESS DOORS</b>	
WB-DW Drywall .....	10
WB-RDW Recessed Drywall .....	10
WB-PL Plaster .....	11
WB-AP Acoustical Plaster .....	11
<b>CEILING ACCESS DOORS</b>	
WB-AT Acoustical Tile .....	12
WB-T-Bar Ceiling .....	12
<b>SECURITY ACCESS DOORS</b>	
WB-MS Medium Security .....	13
WB-HS High Security .....	13
<b>EXTERIOR ACCESS DOORS</b>	
WB-EXT Exterior T Handle .....	14
WB-WTD Walk Through .....	14
<b>SPECIALTY ACCESS DOORS</b>	
WB-MAP Plastic Multi-functional .....	15
WB-GYP Gypsum Panel .....	15
WB-NTG Trimless Gypsum .....	16
<b>ACCESS DOOR WARRANTY</b> .....	16
<b>ACCESSORIES</b> .....	17

# WB-GP PREMIUM GENERAL PURPOSE ACCESS DOOR



The WB-GP Premium General Purpose Access Door is a precision-flush access door for wall and ceiling applications. The frame is laser cut from one sheet of cold rolled steel with no corner mitering and is the aesthetic preference of architects and building professionals alike.

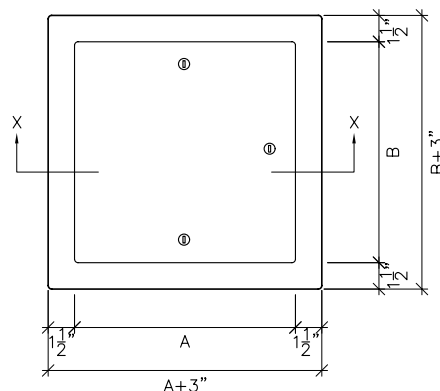

Elevation

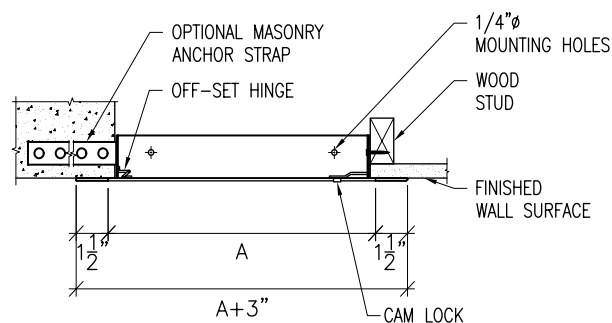

Section Detail

<b>Door and Trim</b>	14 ga. cold rolled steel, trim 1 1/2" wide
<b>Return Frame</b>	18 ga. cold rolled steel, depth of 1 3/4"
<b>Hinge</b>	Fully-concealed off set hinge. Allows opening to 170°. Number of hinges varies with size of door and will be placed on long side of door unless otherwise requested.
<b>Latch</b>	Flush, stainless steel cam operated with screwdriver. Doors over 24" will have semi-concealed piano-type hinge.
<b>Finish</b>	White powder coat paintable finish
<b>Options</b> (at extra cost)	<ul style="list-style-type: none"> <li>• Tamper Proof Cams, Hex, Torx Pin Screw Assembly</li> <li>• Key Cylinder Lock with key (code 151)</li> <li>• Mortise Lock Preparation</li> <li>• Air-tight Neoprene Gasketing</li> <li>• Stainless Steel #304 or #316 (#4 satin finish)</li> <li>• Galvanized/Zinc Coating Finish</li> <li>• Masonry Anchor Straps</li> <li>• Custom Sizes Available</li> </ul>

Model No.	A x B Door Size	Hinges	Cam Latch	Shipping Weight (lbs) Steel/Stainless
WB-GP 6x6	6" x 6"	1	1	4
WB-GP 8x8	8" x 8"	1	1	5
WB-GP 8x12	8" x 12"	1	1	6
WB-GP 8x16	8" x 16"	2	3	8
WB-GP 10x10	10" x 10"	1	1	6
WB-GP 12x12	12" x 12"	1	3	8
WB-GP 12x16	12" x 16"	2	3	10
WB-GP 12x18	12" x 18"	2	3	11
WB-GP 12x24	12" x 24"	3	4	14
WB-GP 14x14	14" x 14"	2	3	10
WB-GP 16x16	16" x 16"	2	3	13
WB-GP 16x20	16" x 20"	3	3	16
WB-GP 16x24	16" x 24"	3	4	17
WB-GP 18x18	18" x 18"	3	3	14
WB-GP 18x24	18" x 24"	3	4	18
WB-GP 18x36	18" x 36"	PH	5	29

Model No.	A x B Door Size	Hinges	Cam Latch	Shipping Weight (lbs) Steel/Stainless
WB-GP 20x20	20" x 20"	3	3	17
WB-GP 20x24	20" x 24"	3	4	21
WB-GP 20x30	20" x 30"	PH	4	23
WB-GP 22x22	22" x 22"	3	4	22
WB-GP 22x24	22" x 24"	3	4	23
WB-GP 22x30	22" x 30"	PH	4	25
WB-GP 22x36	22" x 36"	PH	5	32
WB-GP 24x24	24" x 24"	3	4	24
WB-GP 24x30	24" x 30"	PH	4	27
WB-GP 24x36	24" x 36"	PH	5	35
WB-GP 24x48	24" x 48"	PH	6	43
WB-GP 30x30	30" x 30"	PH	6	32
WB-GP 30x36	30" x 36"	PH	7	39
WB-GP 36x36	36" x 36"	PH	9	44
WB-GP 36x48	36" x 48"	PH	10	57
WB-GP 48x48	48" x 48"	PH	12	70

Rough wall opening = door size + 1/4"  
PH = Full length piano hinge

# WB-UAD UTILITY ACCESS DOOR



<b>Door and Trim</b>	16 ga. cold rolled steel, trim 1 1/2" wide
<b>Return Frame</b>	16 ga. cold rolled steel, depth of 1 3/4"
<b>Hinge</b>	Spring pin hinge up to 24" x 24" Piano hinge on doors larger than 24" x 24"
<b>Latch</b>	Flush, stainless steel cam operated with screwdriver. Latches are positioned opposite hinge as well as top and bottom on larger sizes.
<b>Finish</b>	White powder coat paintable finish
<b>Options</b> (at extra cost)	<ul style="list-style-type: none"> <li>• Tamper Proof Cams, Hex, Torx Pin screw assembly</li> <li>• Key Cylinder Lock with key (code 151)</li> <li>• Mortise Lock Preparation</li> <li>• Stainless Steel #304 or #316 (#4 satin finish)</li> <li>• Galvanized/Zinc Coating Finish</li> <li>• Custom Sizes Available</li> </ul>

The WB-UAD Utility Access Door is an innovative, cost-effective access door. This door is laser cut from 16-gauge cold rolled steel and of uniweld construction that allows for an aesthetically pleasing appearance and square fit for wall and ceiling applications. This door features a spring-loaded pin hinge that allows the door panel to be removed.

Model No.	A x B Door Size	Cam Latch	Shipping Weight (lbs) Steel/Stainless
WB-UAD 6x6	6" x 6"	1	1
WB-UAD 8x8	8" x 8"	1	3
WB-UAD 8x12	8" x 12"	1	4.1
WB-UAD 10x10	10" x 10"	1	4.1
WB-UAD 12x12	12" x 12"	1	5
WB-UAD 14x14	14" x 14"	3	6
WB-UAD 16x16	16" x 16"	3	6.8
WB-UAD 18x18	18" x 18"	3	10
WB-UAD 18x24	18" x 24"	3	14.1
WB-UAD 20x20	20" x 20"	3	11
WB-UAD 22x22	22" x 22"	4	14.4
WB-UAD 22x30	22" x 30"	4	16.1
WB-UAD 22x36	22" x 36"	5	17.1
WB-UAD 24x24	24" x 24"	4	15
WB-UAD 24x30	24" x 30"	4	19.5
WB-UAD 24x36	24" x 36"	5	22.5
WB-UAD 24x48	24" x 48"	6	30
WB-UAD 30x30	30" x 30"	6	24
WB-UAD 36x36	36" x 36"	9	34

Rough wall opening = door size + 1/8"

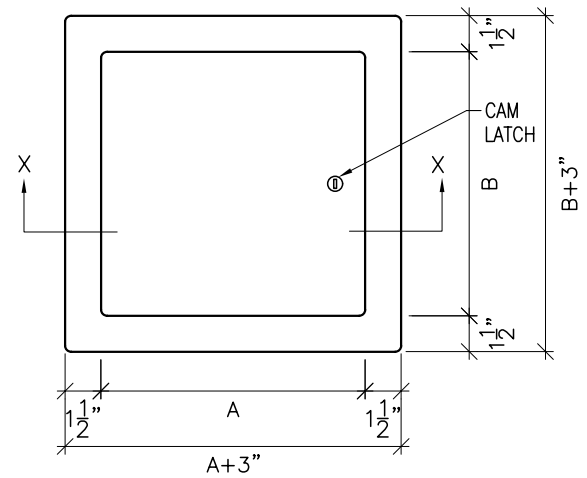

Elevation

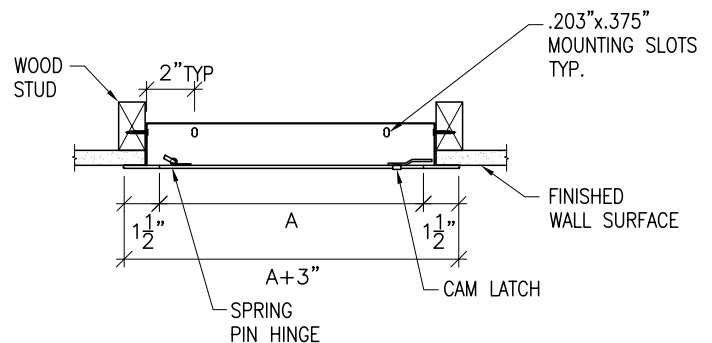

Section Detail

# WB-BASIC ACCESS DOOR



<b>Door and Trim</b>	18 ga. satin coat galvanized steel
<b>Return Frame</b>	18 ga. satin coat galvanized steel
<b>Hinge</b>	Pin hinge top and bottom Allows opening to 165°. Piano hinge on doors larger than 24" x 24"
<b>Latch</b>	Flush, stainless steel cam operated with screwdriver. Latches are positioned opposite hinge as well as top and bottom on larger sizes.

<b>Finish</b>	White powder coat paintable finish
<b>Options</b> (at extra cost)	<ul style="list-style-type: none"> <li>• Key Cylinder Lock with key (code 151)</li> <li>• Stainless Steel #304 or #316 (#4 satin finish)</li> </ul>

\* Piano hinge on doors larger than 24" x 24"

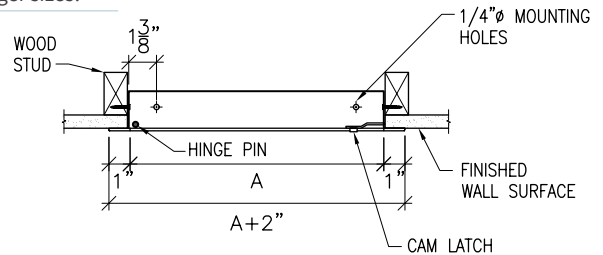

The WB-Basic Access Door is a cost-effective solution, perfect for bidding on any project. This door is manufactured from satin-coat galvanized steel, powder coat white and available in a range of popular sizes, ready for installation. It is easily installed using prelocated mounting holes.

Model No.	A x B Door Size	Cam Latch	Shipping Weight (lbs) Steel/Stainless
WB-Basic 6x6	6" x 6"	1	2
WB-Basic 8x8	8" x 8"	1	3
WB-Basic 10x10	10" x 10"	1	4
WB-Basic 12x12	12" x 12"	1	5
WB-Basic 14x14	14" x 14"	3	6
WB-Basic 16x16	16" x 16"	3	8

Model No.	A x B Door Size	Cam Latch	Shipping Weight (lbs) Steel/Stainless
WB-Basic 18x18	18" x 18"	3	11
WB-Basic 22x22	22" x 22"	4	15
WB-Basic 24x24	24" x 24"	4	17
WB-Basic 24x36	24" x 36"	5	16
WB-Basic 24x48	24" x 48"	6	23
WB-Basic 30x30	30" x 30"	6	19

Rough wall opening = door size + 1/4"

# WB-NT NO TRIM ACCESS DOOR



<b>Door and Trim</b>	16 ga. cold rolled steel
<b>Return Frame</b>	18 ga. cold rolled steel
<b>Hinge</b>	Fully concealed off-set hinge
<b>Latch</b>	Flush, stainless steel cam
<b>Finish</b>	White powder coat paintable finish

<b>Options</b> (at extra cost)	<ul style="list-style-type: none"> <li>• Tamper Proof Cam Hex, Torx Pin Screw Assembly</li> <li>• Key Cylinder Lock with key (code 151)</li> <li>• Mortise Lock Preparation</li> <li>• Stainless Steel #304 or #316 (#4 satin finish)</li> </ul>
-----------------------------------	--

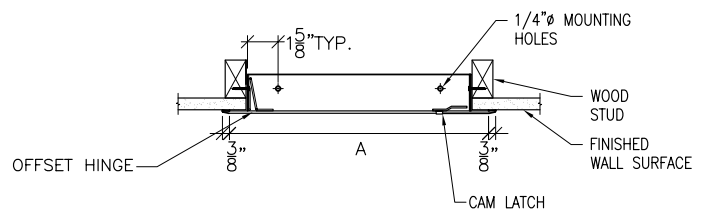

The WB-NT No Trim Access Door features a seamless look. An attractive beveled edge door and micro-rounded corners make this an architect favorite. The door features an off-set hinge that allows it to open 180 degrees, while completely hiding the frame from view.

Model No.	A x B Door Size	Cam Latch	Shipping Weight (lbs) Steel/Stainless
WB-NT 8x8	8" x 8"	1	3
WB-NT 10x10	10" x 10"	1	4
WB-NT 12x12	12" x 12"	1	6
WB-NT 14x14	14" x 14"	1	7
WB-NT 16x16	16" x 16"	1	9

Model No.	A x B Door Size	Cam Latch	Shipping Weight (lbs) Steel/Stainless
WB-NT 18x18	18" x 18"	3	10
WB-NT 20x20	20" x 20"	3	13
WB-NT 22x22	22" x 22"	4	15
WB-NT 24x24	24" x 24"	4	17

Rough wall opening = door size + 1/4"

## WB-RP REMOVABLE PANEL ACCESS DOOR

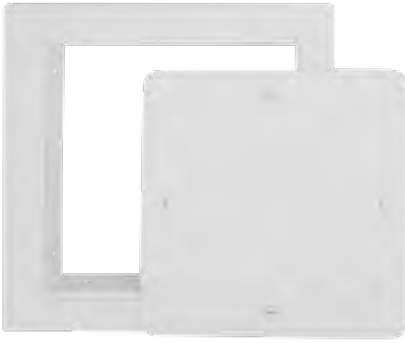

<b>Door and Trim</b>	14 ga. steel, trim 1 1/2" wide
<b>Return Frame</b>	18 ga. steel, depth of 1 3/4"
<b>Latch</b>	Flush, stainless steel cam operated with screwdriver on all 4 sides
<b>Finish</b>	White powder coat paintable finish
<b>Options (at extra cost)</b>	<ul style="list-style-type: none"> <li>Tamper Proof Cams, Hex, Torx Pin Screw Assembly</li> <li>Key Cylinder Lock with key (code 151)</li> </ul>

<b>Options (at extra cost)</b>	<ul style="list-style-type: none"> <li>Mortise Lock Preparation</li> <li>Air-Tight Neoprene Gasketing</li> <li>Stainless Steel #304 or #316 (#4 satin finish)</li> <li>Galvanized/Zinc Coating Finish</li> <li>Masonry Anchor Straps</li> <li>Custom Sizes Available</li> </ul>
--------------------------------	---

The WB-RP Removable Panel Access Door is designed with the same quality features as the GP Premium Door, but it is primarily designed for use in confined spaces. The door panel can be easily removed by unscrewing the cam latches. The frame is laser cut from one sheet of steel for visual aesthetics. As an optional feature, gasketing allows this door to be used for an air tight or dust free application.

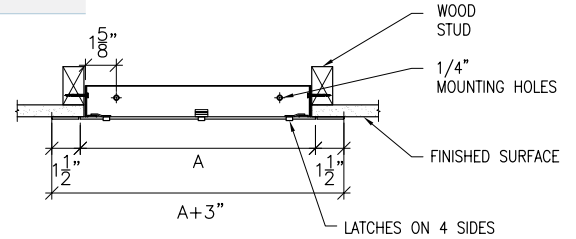

Model No.	A x B Door Size	Cam Latch	Shipping Weight (lbs)
WB-RP 8x8	8" x 8"	4	3
WB-RP 12x12	12" x 12"	4	8
WB-RP 16x16	16" x 16"	4	10

Model No.	A x B Door Size	Cam Latch	Shipping Weight (lbs)
WB-RP 18x18	18" x 18"	4	13
WB-RP 24x24	24" x 24"	8	20

Rough wall opening = door size + 1/4"

## WB-SMP SURFACE MOUNTED PANEL ACCESS DOOR



<b>Door and Trim</b>	14 ga. steel, trim 1 1/2" wide
<b>Door Stops</b>	16 ga. on 3 sides of door opening
<b>Hinge</b>	Full length piano hinge allows door to be opened to 180°. Will be placed on long side of door unless otherwise requested.
<b>Latch</b>	Flush, stainless steel cam operated with screwdriver. Latches are positioned opposite hinge as well as on top and bottom on larger sizes.
<b>Finish</b>	White powder coat paintable finish

<b>Options (at extra cost)</b>	<ul style="list-style-type: none"> <li>Tamper Proof Cams, Hex, Torx Pin Screw Assembly</li> <li>Key Cylinder Lock with key (code 151)</li> <li>Mortise Lock Preparation</li> <li>Neoprene Gasketing</li> <li>Stainless Steel #304 or #316 (#4 satin finish)</li> <li>Galvanized/Zinc Coating Finish</li> <li>Masonry Anchor Straps</li> <li>Custom Sizes Available</li> </ul>
--------------------------------	---

The WB-SMP Surface Mounted Panel Access Door is a door face only, with no return frame. It does not require a framed opening, making it simple to install over any wall and ceiling openings. The door's frame is laser cut from one sheet of steel for visual aesthetics.

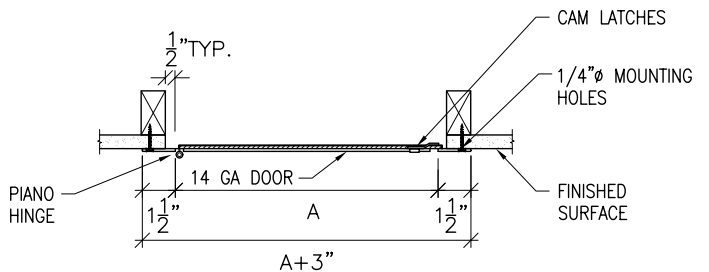

Model No.	A x B Door Size	Wall Opening	Cam Latch	Shipping Weight (lbs) Steel/Stainless
WB-SMP 8x8	8" x 8"	TO SUIT DOOR PANEL	1	4
WB-SMP 12x12	12" x 12"		3	5
WB-SMP 16x16	16" x 16"		3	10
WB-SMP 18x18	18" x 18"		3	14
WB-SMP 24x24	24" x 24"		4	18

# WB-AL ALUMINUM INSULATED ACCESS DOOR



<b>Door and Trim</b>	.063 Aluminum, trim 1 1/2" wide
<b>Return Frame</b>	.063 Aluminum, depth of 2"
<b>Hinge</b>	Continuous rod hinge
<b>Latches</b>	Flush aluminum steel cam
<b>Insulation</b>	1" AMVIC <i>SilveRboard Ridge Foam Insulation</i> with a R5 Value

<b>Gasket</b>	Neoprene gasket included on 4 sides
<b>Finish</b>	Mill finish
<b>Options</b> (at extra cost)	Key medium barrel cylinder Lock with key (code 151)

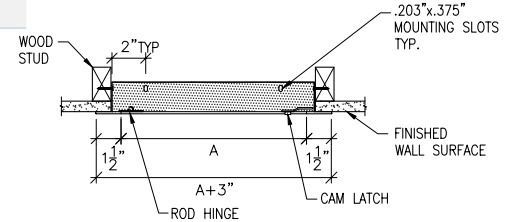

The WB-AL Aluminum Insulated Access Door is a light weight insulated aluminum access door. It is ideal for exterior applications, and also those specific interior applications where corrosion or moisture is a concern. The aluminum panel is insulated with 1" *SilveRboard Ridge Foam Insulation*. Access to large openings in walls and ceilings is made easy. The non-extruded door frame has the same visual aesthetic design as the UAD door. Weather resistant neoprene gasketing is installed on 4 sides.

Model No.	A x B Door Size	Cam Latch	Shipping Weight (lbs) Steel/Stainless
WB-AL 8x8	8" x 8"	1	3.5
WB-AL 12x12	12" x 12"	3	6
WB-AL 16x16	16" x 16"	3	9
WB-AL 18x18	18" x 18"	3	15
WB-AL 24x24	24" x 24"	4	24
WB-AL 24x36	24" x 36"	5	45

Rough wall opening = door size + 1/4"

# WB-ALU ALUMINUM UNINSULATED ACCESS DOOR



<b>Door and Trim</b>	.060 Aluminum, trim 1 3/4" wide
<b>Return Frame</b>	.060 Aluminum, depth of 1 1/16"
<b>Hinge</b>	Full length piano hinge
<b>Latch</b>	Flush aluminum cam

<b>Finish</b>	White powder coat paintable finish
<b>Options</b> (at extra cost)	<ul style="list-style-type: none"> <li>Key cylinder lock with key (code 151)</li> <li>Neoprene Gasketing</li> </ul>

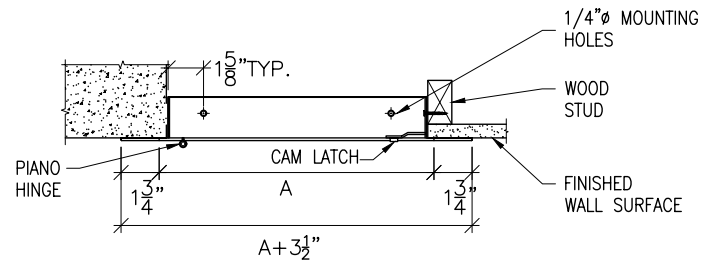

The WB-ALU Uninsulated Aluminum Access Door is a lightweight aluminum access door for wall and ceiling application. Its surround trim is welded on all 4 sides to the return frame providing strength and rigidity. It features radius corners and no corner mitering. Its aesthetic appearance makes it an architect favorite.

Model No.	A x B Door Size	Cam Latch	Shipping Weight (lbs) Steel/Stainless
WB-ALU 6x6	6" x 6"	1	2.5
WB-ALU 8x8	8" x 8"	1	3.5
WB-ALU 8x12	8" x 12"	1	5
WB-ALU 10x10	10" x 10"	1	5
WB-ALU 12x12	12" x 12"	1	6
WB-ALU 12x16	12" x 16"	3	7.5
WB-ALU 12x18	12" x 18"	3	8
WB-ALU 12x24	12" x 24"	3	10
WB-ALU 14x14	14" x 14"	3	7.5
WB-ALU 16x16	16" x 16"	3	9
WB-ALU 18x18	18" x 18"	3	15
WB-ALU 18x24	18" x 24"	4	13
WB-ALU 18x36	18" x 36"	5	29

Model No.	A x B Door Size	Cam Latch	Shipping Weight (lbs) Steel/Stainless
WB-ALU 20x20	20" x 20"	3	19
WB-ALU 22x22	22" x 22"	4	21
WB-ALU 22x30	22" x 30"	5	27
WB-ALU 22x36	22" x 36"	5	30
WB-ALU 24x24	24" x 24"	4	24
WB-ALU 24x30	24" x 30"	4	28
WB-ALU 24x36	24" x 36"	5	32
WB-ALU 24x48	24" x 48"	6	40
WB-ALU 30x30	30" x 30"	6	34
WB-ALU 36x36	36" x 36"	9	45
WB-ALU 36x48	36" x 48"	10	57
WB-ALU 48x48	48" x 48"	12	70

Rough wall opening = door size + 1/4"



# WB-FR STANDARD FIRE RATED ACCESS DOOR



## WB-FR S

<b>Door and Trim</b>	18 ga. cold rolled steel
<b>Box Return Frame</b>	16 ga. cold rolled steel
<b>Insulation</b>	2" thick mineral wool contained within door cavity
<b>Hinge</b>	Fully concealed rod type hinge. Allows opening to 170°.
<b>Latch</b>	Self-latching direct-action latch, opposite hinge. Accepts both key and knurled knob, included with each door.
<b>Automatic Panel Closer</b>	Standard on all doors
<b>Inside Panel Release</b>	Standard on all doors
<b>Finish</b>	White powder coat paintable finish
<b>Masonry Anchor Straps</b>	Standard on all doors
<b>Options</b> (at extra cost)	<ul style="list-style-type: none"> <li>• Mortise lock preparation</li> <li>• Stainless steel #304 and #316 (#4 satin finish)</li> <li>• Pemko hot smoke seal gasketing</li> <li>• Custom sizes available</li> </ul>
<b>Ceiling Installation</b>	To comply with current fire regulations, largest size acceptable is 24" x 36"

The WB-FR Standard Fire Rated Access Door is designed for both wall and ceiling applications. For walls, this door has an Underwriters Laboratories (UL and ULC), 1-1/2 hour "B" label, with a maximum temperature rise of 250 degrees Celsius after 30 minutes for vertical wall installations. Warnock Hersey International; Pittsburgh, CA 1 hr rating for combustible floor/ceiling applications. 3 Hr. rating for non-combustible floor/ceiling assembly. This door may be used in a 2-hour fire rated wall assembly. For fire rated ceilings, this door has been approved by Warnock Hersey International for 3 hours (\*max. size to 24" x 36"). Intertek Spec. ID #57683.

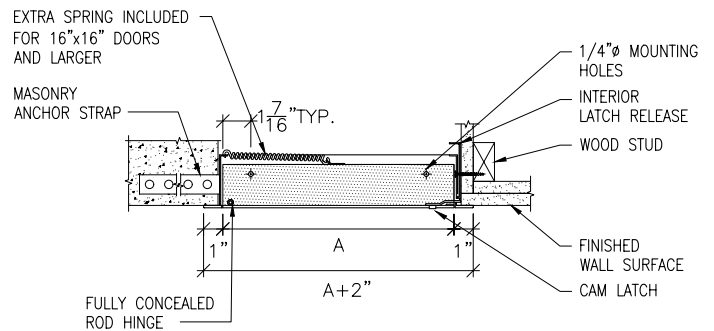

# WB-FR STANDARD ULTRA FIRE RATED ACCESS DOOR



The WB-FR Standard Ultra Access Door features a paddle latch with WB 151 key cylinder lock.



## WB-FR S ULTRA

## WB-FR STANDARD AND ULTRA ACCESS DOORS

For WB-FR Standard use WB-FRS

For WB-FR Ultra use WB-FRS-U

Model No.	A x B Door Size	Slam Catch	Hinges	Shipping Weight (lbs) Steel/Stainless
WB-FRS 8x8	8" x 8"	1	1	7
WB-FRS 10x10	10" x 10"	1	1	10
WB-FRS 12x12	12" x 12"	1	1	11
WB-FRS 12x18	12" x 18"	1	1	19
WB-FRS 12x24	12" x 24"	1	1	18
WB-FRS 14x14	14" x 14"	1	1	15
WB-FRS 16x16	16" x 16"	1	1	18
WB-FRS 18x18	18" x 18"	1	1	21
WB-FRS 18x24	18" x 24"	1	1	26
WB-FRS 20x20	20" x 20"	1	1	26
WB-FRS 20x30	20" x 30"	2	1	38
WB-FRS 21x36	21" x 36"	2	1	43
WB-FRS 22x22	22" x 22"	1	1	29
WB-FRS 22x24	22" x 24"	1	1	30
WB-FRS 22x30	22" x 30"	2	1	37

Model No.	A x B Door Size	Slam Catch	Hinges	Shipping Weight (lbs) Steel/Stainless
WB-FRS 22x36	22" x 36"	2	1	43
WB-FRS 24x24	24" x 24"	1	1	31
WB-FRS 24x30	24" x 30"	2	1	40
WB-FRS 24x36	24" x 36"	2	1	46
WB-FRS 24x48	24" x 48"	2	1	62
WB-FRS 30x30	30" x 30"	2	1	50
WB-FRS 32x32	32" x 32"	2	1	54
WB-FRS 36x36	36" x 36"	2	1	67
WB-FRS 36x48	36" x 48"	2	1	83
WB-FRS 48x48	48" x 48"	2	1	104

Rough wall opening = door size + 1/4"

Note: For fire-rated ceiling access doors, on size 16" x 16" and larger, extra spring supplied with door must be attached from back of door pan to framing or floor above. In horizontal (ceiling) applications door has self-assisted closing.



# WB-FR BASIC UNINSULATED FIRE RATED ACCESS DOOR



The WB-FR Basic Uninsulated Fire Rated Access Door is designed for wall application only. It is not insulated and should only be installed in environments where temperature rise is not a concern. It features a 1 1/2" trim for an easy flush application into various wall finishes. UL Listed "B" label for 1-1/2 hours. File # R10364C UL US.



<b>Door and Trim</b>	14 ga. cold rolled steel
<b>Box Return Frame</b>	16 ga. cold rolled steel, 2 1/2" deep frame
<b>Hinge</b>	180° full length piano hinge
<b>Latch</b>	Self latching lock with key and knurled knob
<b>Automatic Door Closer</b>	Standard on all doors
<b>Inside Release Latch</b>	Standard on all doors
<b>Finish</b>	White powder coat paintable finish
<b>Options</b> (at extra cost)	<ul style="list-style-type: none"> <li>Mortise lock preparation</li> <li>Stainless steel #304 and #316 (#4 satin finish)</li> <li>Masonry anchor straps</li> <li>Custom sizes available</li> </ul>

Note: WB-FR BASIC access doors are for vertical applications only as code allows and no temperature rise is required.

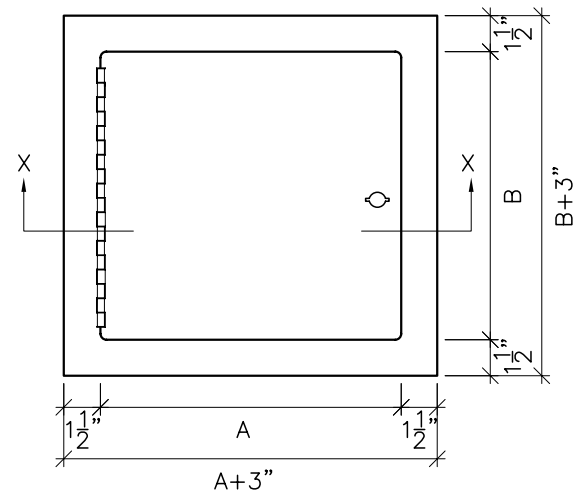

Elevation

Model No.	A x B Door Size	Slam Latch	Shipping Weight (lbs) Steel/Stainless
WB-FRB 8x8	8" x 8"	1	6
WB-FRB 10x10	10" x 10"	1	9
WB-FRB 12x12	12" x 12"	1	11
WB-FRB 14x14	14" x 14"	1	14
WB-FRB 16x16	16" x 16"	1	17
WB-FRB 18x18	18" x 18"	1	21
WB-FRB 20x20	20" x 20"	1	24
WB-FRB 22x22	22" x 22"	1	28
WB-FRB 22x30	22" x 30"	2	29
WB-FRB 22x36	22" x 36"	2	30
WB-FRB 24x24	24" x 24"	1	26
WB-FRB 24x30	24" x 30"	2	43
WB-FRB 24x36	24" x 36"	2	38
WB-FRB 30x30	30" x 30"	2	50

Rough wall opening = door size + 1/4"

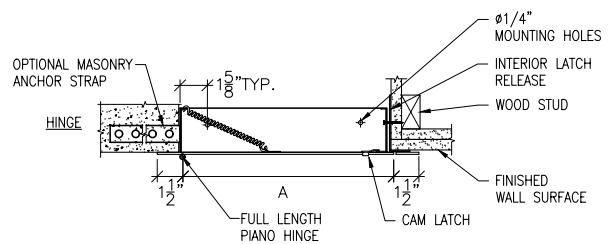

Section Detail

# WB-FR STANDARD DRYWALL FIRE RATED ACCESS DOOR



<b>Door and Trim</b>	18 ga. cold rolled steel
<b>Box Return Frame</b>	16 ga. cold rolled steel, 1" wide perforated flange of 24 ga. galvanized drywall bead
<b>Insulation</b>	2" thick mineral wool contained within door cavity
<b>Hinge</b>	Fully concealed rod hinge. Allows opening to 170°.
<b>Latch</b>	Self-latching direct action latch, opposite hinge. Accepts both key and knurled knob, included with each door.
<b>Automatic Panel Closer</b>	Standard on all doors

<b>Inside Panel Release</b>	Standard on all doors
<b>Finish</b>	White powder coat paintable finish
<b>Masonry Anchor Straps</b>	Standard on all doors
<b>Options (at extra cost)</b>	<ul style="list-style-type: none"> <li>Mortise lock preparation</li> <li>Ultra lock with key (code 151)</li> <li>Stainless steel #304 and #316 (#4 satin finish)</li> <li>Pemko smoke seal gasketing</li> <li>Custom sizes available</li> </ul>
<b>Ceiling Installation</b>	To comply with current fire regulations, largest size acceptable is 24" x 36"

Model No.	A x B Door Size	Slam Catch	Hinges	Shipping Weight (lbs) Steel/Stainless
WB-FR DW 12x12	12" x 12"	1	1	12
WB-FR DW 14x14	14" x 14"	1	1	15
WB-FR DW 16x16	16" x 16"	1	1	18
WB-FR DW 18x18	18" x 18"	1	1	21
WB-FR DW 24x24	24" x 24"	1	1	32
WB-FR DW 24x36	24" x 36"	2	1	46

Rough wall opening = door size + 1/4"

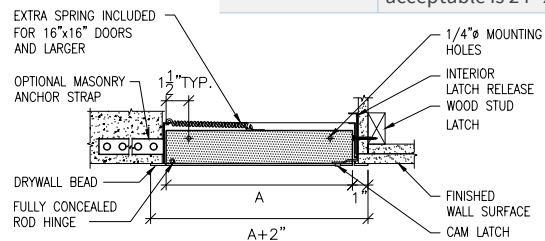

# WB-FR STANDARD PLASTER FIRE RATED ACCESS DOOR



<b>Door and Trim</b>	18 ga. cold rolled steel
<b>Box Return Frame</b>	16 ga. cold rolled steel, 3" wide perforated plaster flange of 24 ga. galvanized material. Space from the plaster mesh flange to the 1/4" safety edge of the door will accommodate 1" of plaster mud.
<b>Insulation</b>	2" thick mineral wool contained within door cavity
<b>Hinge</b>	Fully concealed rod hinge. Allows opening to 170°.
<b>Latch</b>	Self-latching direct action latch, opposite hinge. Accepts both key and knurled knob, included with each door.
<b>Automatic Panel Closer</b>	Standard on all doors

<b>Inside Panel Release</b>	Standard on all doors
<b>Finish</b>	White powder coat paintable finish
<b>Masonry Anchor Straps</b>	Standard on all doors
<b>Options (at extra cost)</b>	<ul style="list-style-type: none"> <li>Mortise lock preparation</li> <li>Ultra lock with key (code 151)</li> <li>Stainless steel #304 and #316 (#4 satin finish)</li> <li>Pemko smoke seal gasketing</li> <li>Custom sizes available</li> </ul>
<b>Ceiling Installation</b>	To comply with current fire regulations, largest size acceptable is 24" x 36"

Model No.	A x B Door Size	Hinges	Slam Catch	Shipping Weight (lbs)
WB-FR PL 12x12	12" x 12"	1	1	12
WB-FR PL 14x14	14" x 14"	1	1	15
WB-FR PL 16x16	16" x 16"	1	1	18
WB-FR PL 18x18	18" x 18"	1	1	21
WB-FR PL 24x24	24" x 24"	1	1	32
WB-FR PL 24x36	24" x 36"	1	2	46

Rough wall opening = door size + 1/4"

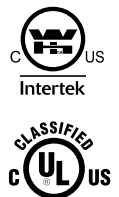
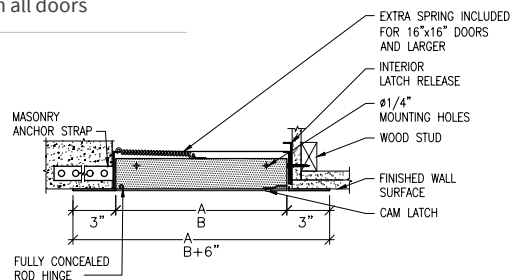

Both WB-FR Standard Plaster and Drywall Access Doors feature a tape-in flange that allows for a trimless appearance to eliminate visual distraction without compromising the fire rating. They are designed for both wall and ceiling applications. This door has an Underwriters Laboratories (UL and ULC), 1-1/2 hour "B" label, with a maximum temperature rise of 250 degrees Celsius after 30 minutes for vertical wall installations. Warnock Hersey International; Pittsburgh, CA 1 hour rating for combustible floor/ceiling

applications. 3 Hour. rating for non-combustible floor/ceiling assembly. These doors may be used in a 2-hour fire rated wall assembly. For fire rated ceilings, these doors have been approved by Warnock Hersey International for 3 hours (\*max. size to 24" x 36"). Intertek Spec. ID #57683.

Note: For fire-rated ceiling access doors, on size 16" x 16" and larger, extra spring supplied with door must be attached from back of door pan to framing or floor above. In horizontal (ceiling) applications door has self-assisted closing.

## WB-DW DRYWALL ACCESS DOOR



<b>Door and Trim</b>	16 ga. cold rolled steel door with 1" drywall bead and 24 ga. galvanized steel trim for mounting purposes
<b>Frame</b>	16 ga. cold rolled steel
<b>Hinge</b>	Fully-concealed off-set hinge up to and including 24"x24". Number of hinges varies with size of the door and will be placed on long side of door unless otherwise specified. Doors larger than 24"x24" have full length piano hinge.

<b>Latch</b>	Flush, stainless steel cam operated with screwdriver. Latches are positioned opposite hinge as well as top and bottom on larger sizes.
<b>Finish</b>	White powder coat paintable finish
<b>Options (at extra cost)</b>	<ul style="list-style-type: none"> <li>• Key Cylinder Lock with key (code 151)</li> <li>• Air-tight Neoprene Gasketing</li> <li>• Stainless Steel #304 or #316 (#4 satin finish)</li> </ul>

The WB-DW Drywall Access Door has the same quality features as the WB-GP Premium with a tape-in drywall flange. This is designed to eliminate visual distraction, by allowing drywall cement to be applied to cover the flange at the time of installation.

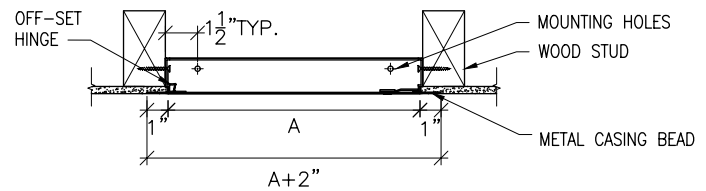

Model No.	A x B Door Size	Hinges	Cam Latch	Shipping Weight (lbs) Steel/Stainless
WB-DW 8x8	8" x 8"	1	1	3
WB-DW 10x10	10" x 10"	1	1	5
WB-DW 12x12	12" x 12"	1	3	7
WB-DW 12x24	12" x 24"	3	2	12
WB-DW 14x14	14" x 14"	2	3	9
WB-DW 16x16	16" x 16"	2	3	11
WB-DW 18x18	18" x 18"	2	3	12
WB-DW 22x22	22" x 22"	3	4	18

Model No.	A x B Door Size	Hinges	Cam Latch	Shipping Weight (lbs) Steel/Stainless
WB-DW 22x30	22" x 30"	PH	4	24
WB-DW 22x36	22" x 36"	PH	5	27
WB-DW 24x24	24" x 24"	3	4	20
WB-DW 24x36	24" x 36"	PH	5	27
WB-DW 24x48	24" x 48"	PH	6	37
WB-DW 30x30	30" x 30"	PH	6	29
WB-DW 30x36	30" x 36"	PH	7	31
WB-DW 36x36	36" x 36"	PH	9	42

Rough wall opening = door size + 1/4"

PH = Full length piano hinge

## WB-RDW RECESSED DRYWALL ACCESS DOOR



<b>Door and Trim</b>	16 ga. cold rolled steel. Door is recessed 5/8" to accept drywall.
<b>Frame</b>	16 ga. cold rolled steel. 1" wide perforated 24 ga. galvanized steel for mounting purposes.
<b>Hinge</b>	Fully concealed rod type hinge, will be placed on long side of door unless otherwise requested.

<b>Latch</b>	Flush, stainless steel cam operated with screwdriver. Latches are positioned opposite hinge as well as top and bottom on larger sizes.
<b>Finish</b>	White powder coat paintable finish
<b>Options (at extra cost)</b>	<ul style="list-style-type: none"> <li>• Medium barrel cylinder lock</li> <li>• Drywall with door</li> <li>• Air-tight Neoprene Gasketing</li> </ul>

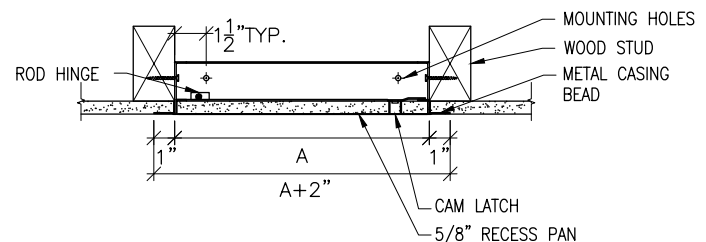

The WB-RDW Recessed Drywall Access Door features a 5/8" recessed pan that gives the option of installing a matching piece of drywall into the door panel, keeping the continuity of the visual area. The outdoor frame has a tape-in flange so that the unit may be cemented in place at the time of installation.

Model No.	A x B Door Size	Hinges	Cam Latch	Shipping Weight (lbs) Steel/Stainless
WB-RDW 12x12	12" x 12"	1	1	6
WB-RDW 12x24	12" x 24"	1	4	13
WB-RDW 16x16	16" x 16"	1	3	12
WB-RDW 18x18	18" x 18"	1	3	13
WB-RDW 24x24	24" x 24"	1	4	21
WB-RDW 24x36	24" x 36"	1	5	32

Rough wall opening = door size + 1/4"

## WB-PL PLASTER ACCESS DOOR



<b>Door and Trim</b>	16 ga. cold rolled steel
<b>Box Return Frame</b>	16 ga. steel. 3" wide plaster mesh flange of 24 ga. galvanized material. Space from the expanded flange to the 1/4" safety edge of the door will accommodate 1" of plaster.
<b>Hinge</b>	Fully-concealed off-set hinge. Number of hinges varies with size of door and will be placed on long side of door unless otherwise requested. Doors larger than 24"x24" have full length piano hinge.

<b>Latch</b>	Flush, stainless steel cam operated with screwdriver. Latches are positioned opposite hinge as well as top and bottom on larger sizes.
<b>Finish</b>	White powder coat paintable finish
<b>Options</b> (at extra cost)	<ul style="list-style-type: none"> <li>Key Cylinder Lock with key (code 151)</li> <li>Air-tight Neoprene Gasketing</li> <li>Stainless Steel #304 or #316 (#4 satin finish)</li> </ul>

The WB-PL Plaster Access Door is a flush door designed for wall and ceiling application, featuring a tape-in plaster bead. This allows for plaster mud to be applied to the flange concealing it. The 1/4" safety edge gives the door a strong frame and prevents the plaster from being chipped under normal use.

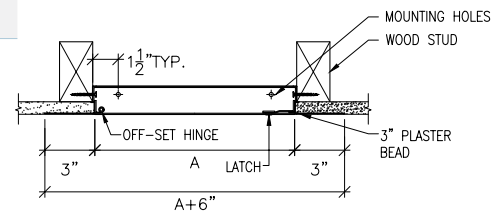

Model No.	A x B Door Size	Hinges	Cam Latch	Shipping Weight (lbs) Steel/Stainless
WB-PL 8x8	8" x 8"	1	1	4
WB-PL 8x12	8" x 12"	2	1	6
WB-PL 10x10	10" x 10"	1	1	5
WB-PL 12x12	12" x 12"	2	1	7
WB-PL 12x16	12" x 16"	2	3	8
WB-PL 12x18	12" x 18"	2	3	8
WB-PL 14x14	14" x 14"	2	3	10
WB-PL 16x16	16" x 16"	2	3	12

Model No.	A x B Door Size	Hinges	Cam Latch	Shipping Weight (lbs) Steel/Stainless
WB-PL 16x20	16" x 20"	2	3	15
WB-PL 18x18	18" x 18"	2	3	13
WB-PL 20x24	20" x 24"	3	4	17
WB-PL 22x22	22" x 22"	3	4	19
WB-PL 24x24	24" x 24"	3	4	20
WB-PL 24x30	24" x 30"	PH	4	24
WB-PL 24x36	24" x 36"	PH	5	30

Rough wall opening = door size + 1/4"

PH = Full length piano hinge

## WB-AP ACOUSTICAL PLASTER ACCESS DOOR

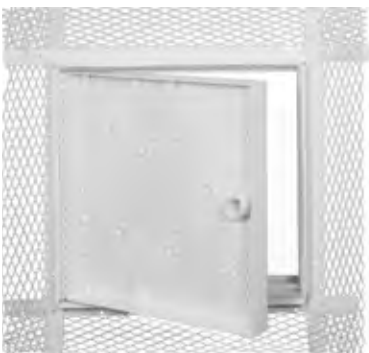

<b>Door</b>	16 ga. cold rolled steel. Door is recessed 5/8" and lined with expanded metal lath
<b>Box Return Frame</b>	16 ga. steel with 24 ga. plaster mesh galvanized casing bead and expanded metal lath surrounding door
<b>Hinge</b>	Full length piano hinge opens 180°, will be placed on long side of door unless otherwise requested

<b>Latch</b>	Flush, stainless steel cam operated with screwdriver
<b>Finish</b>	White powder coat paintable finish
<b>Options</b> (at extra cost)	Medium barrel cylinder lock

The WB-AP Acoustical Plaster Access Door is a precision door that provides a virtually concealed installation, keeping acoustical surfaces intact while contributing to sound control and better appearance. Door panels are recessed to receive plaster up to 5/8" thick. Plaster covering the door finishes flush with the surrounding field, leaving only the narrow frame edges exposed. The metal sides of the recessed door panel prevent damage to the edges of the plaster. This door operates on a continuous stainless steel piano hinge, located at the outside edge so that the door may be opened fully to 180 degrees.

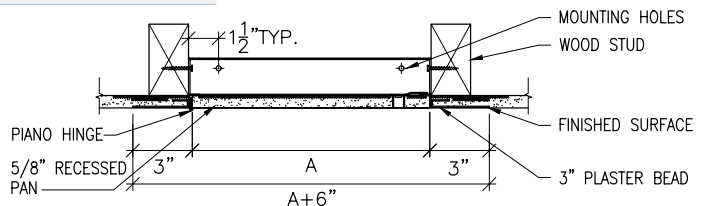

Model No.	A x B Door Size	Hinges	Cam Latch	Shipping Weight (lbs) Steel/Stainless
WB-AP 12x12	12" x 12"	1	1	10
WB-AP 12x24	12" x 24"	1	2	13
WB-AP 18x18	18" x 18"	1	3	15
WB-AP 24x24	24" x 24"	1	4	28
WB-AP 24x36	24" x 36"	1	5	37

Rough wall opening = door size + 1/4"

## WB-AT ACOUSTICAL TILE ACCESS DOOR



<b>Door</b>	16 ga. cold rolled steel. Door is recessed to accept up to 5/8" acoustical tile.
<b>Box Return Frame</b>	16 ga. cold rolled steel
<b>Hinge</b>	Continuous piano hinge opens 180 degrees, will be placed on long side of door unless otherwise requested.

<b>Latches</b>	Flush, stainless steel cam operated with screwdriver. Latches positioned opposite hinge as well as top and bottom on larger sizes.
<b>Finish</b>	White powder coat paintable finish
<b>Options (at extra cost)</b>	Medium Barrel Cylinder Lock

The WB-AT Acoustical Tile Access Door is a precision ceiling door that provides a virtually concealed installation, keeping acoustical surfaces intact while contributing to sound control and better appearance. The door is recessed to accept up to 5/8" thick acoustical tile. Each door comes complete with grommets.

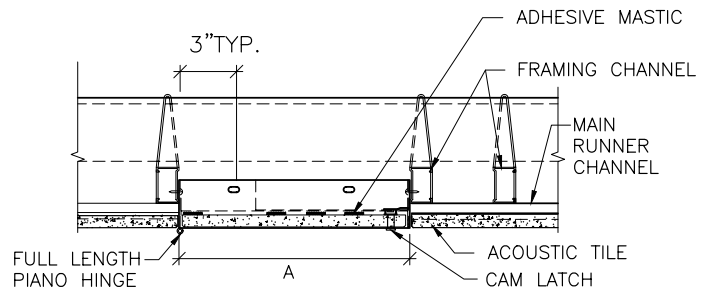

Model No.	A x B Door Size	Hinges	Cam Latch	Shipping Weight (lbs)
WB-AT 12x12	12" x 12"	1	1	8
WB-AT 12x24	12" x 24"	1	2	13
WB-AT 18x18	18" x 18"	1	3	15
WB-AT 24x24	24" x 24"	1	3	25
WB-AT 24x36	24" x 36"	1	5	33

Rough ceiling opening = door size + 1/4"

## WB-T-BAR CEILING ACCESS DOOR



<b>Door</b>	.063 aluminum
<b>Hinge</b>	Continuous piano hinge
<b>Latches</b>	Flush stainless steel cam
<b>Finish</b>	Powder coat white
<b>Options (at extra cost)</b>	Key Cylinder Lock with key (code 151)

The WB-T-Bar Ceiling Access Door is a light weight aluminum door that simply drops into a t-bar ceiling with ease. Included with each door are mounting screws for a safe and secure ceiling installation.

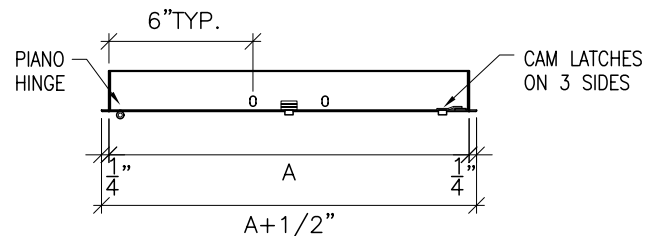

Model No.	A x B Door Size	Ceiling Opening	Cam Latch	Shipping Weight (lbs)
WB-T-BAR 24 x 24	24" x 24"	23 3/4" x 23 3/4"	4	6
WB-T-BAR 24 x 48	24" x 48"	23 3/4" x 47 3/4"	6	11

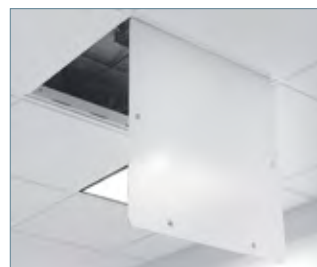

## WB-MS MEDIUM SECURITY ACCESS DOOR



<b>Door &amp; Trim</b>	12 ga. cold rolled steel
<b>Frame</b>	16 ga. cold rolled steel
<b>Hinge</b>	Full length piano hinge
<b>Lock</b>	1/4-20 tamper proof screw assemblies
<b>Finish</b>	White powder coat paintable finish

<b>Options</b> (at extra cost)	<ul style="list-style-type: none"> <li>Stainless steel #304 and #316 (#4 satin finish)</li> <li>Mortise lock preparation with or without cylinder</li> <li>Air-tight Neoprene Gasketing</li> <li>Cylinder lock with key (code 151)</li> </ul>
-----------------------------------	---

The WB-MS Medium Security Access Door is the door of choice when it is necessary to assure security under institutional conditions. Most detention buildings and mental health facilities require access to vital services in or behind walls, shafts and stairwells without jeopardizing security. The door can be customized to accommodate any mortise lock specified.

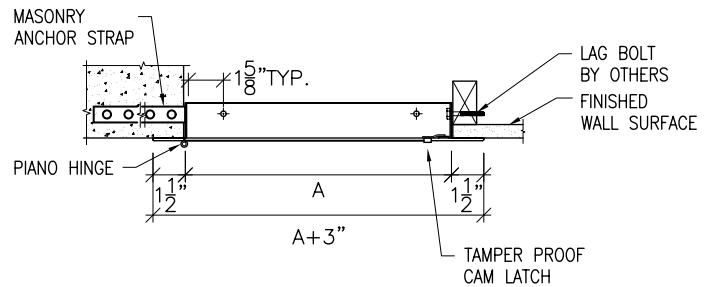

Model No.	A x B Door Size	Full Length Semi-Concealed Piano Hinge	Tamper Proof Screw Locks	Shipping Weight (lbs)
WB-MS 12x12	12" x 12"	1	1	22
WB-MS 16x16	16" x 16"	1	3	31
WB-MS 18x18	18" x 18"	1	3	36

Rough wall opening = door size + 1/4"

Model No.	A x B Door Size	Full Length Semi-Concealed Piano Hinge	Tamper Proof Screw Locks	Shipping Weight (lbs)
WB-MS 24x24	24" x 24"	1	4	52
WB-MS 24x36	24" x 36"	1	5	73
WB-MS 36x36	36" x 36"	1	9	103

## WB-HS HIGH SECURITY ACCESS DOOR



<b>Door &amp; Trim</b>	10 ga. cold rolled steel
<b>Frame</b>	10 ga. cold rolled steel
<b>Hinge</b>	Heavy duty type butt hinges welded to surround and door
<b>Lock</b>	Prepped for detention lock

<b>Finish</b>	White powder coat paintable finish.
<b>Options</b>	<ul style="list-style-type: none"> <li>Stainless steel #304 and #316 (#4 satin finish)</li> <li>Custom sizes</li> <li>Detention lock and paracentric key</li> </ul>

The WB-HS High Security Access Door is designed for installation where maximum security is mandatory. This door comes prepped for a detention lock for controlled access, which is sold separately. It can be prepped for custom mortise locks and requirements.

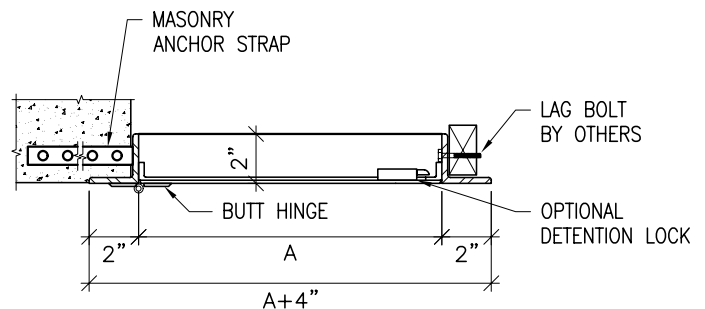

Model No.	A x B Door Size	Heavy Duty Detention Hinges	Shipping Weight (lbs) Steel/Stainless
WB-HS 12x12	12" x 12"	2	46
WB-HS 16x16	16" x 16"	2	56
WB-HS 18x18	18" x 18"	2	62
WB-HS 24x24	24" x 24"	2	82
WB-HS 24x36	24" x 36"	3	134
WB-HS 36x36	36" x 36"	3	140

Rough wall opening = door size + 3/4"

## WB-EXT EXTERIOR T HANDLE ACCESS DOOR



<b>Door &amp; Trim</b>	16 ga. satin coat galvanized steel, trim 1 3/4" wide.
<b>Frame</b>	Continuous stainless steel piano hinge. Allows opening to 180°
<b>Latch</b>	Chrome-plated zinc "T" type handle with pivot rod 3 point catch. Opens from the outside only.
<b>Finish</b>	Powder coat white

<b>Insulation</b>	2" Layer AMVIC <i>SilverBoard Ridge Foam Insulation</i> with a R/O Value 10
<b>Gasket</b>	Open celled microcellular polyurethane on inside of door and closed cell neoprene sponge SC42 W/PSA stripping gasketing on the back of the door
<b>Application</b>	For exterior purposes, weather resistive
<b>Options</b>	Powder coat grey ASA61

The WB-EXT Exterior T Handle Access Door is constructed of galvanized steel and is insulated. It features two types of gasketing: weather resistive open cell microcellular polyurethane gasketing and closed cell neoprene sponge SC42 W/PSA stripping gasketing on the inside for outdoor applications (certain saltwater areas might not be compatible).

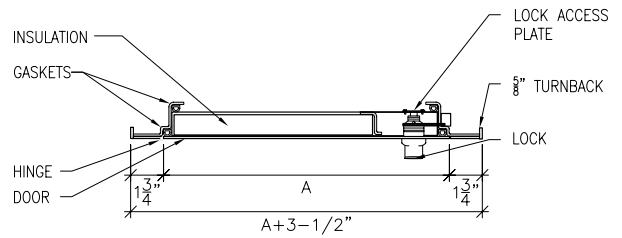

Model No.	A x B Door Size	Shipping Weight (lbs)
WB-EXT 12x12	12" x 12"	27
WB-EXT 14x14	14" x 14"	32
WB-EXT 16x16	16" x 16"	36
WB-EXT 18x18	18" x 18"	41
WB-EXT 22x30	22" x 30"	45
WB-EXT 22x36	22" x 36"	50
WB-EXT 24x24	24" x 24"	55

Model No.	A x B Door Size	Shipping Weight (lbs)
WB-EXT 24x36	24" x 36"	67
WB-EXT 30x30	30" x 30"	75
WB-EXT 30x36	30" x 36"	79
WB-EXT 36x36	36" x 36"	90

Rough wall opening = door size + 1/4"

## WB-WTD WALK THROUGH ACCESS DOOR



<b>Door</b>	22 ga. satin coat
<b>Trim</b>	16 ga. satin coat
<b>Return Frame</b>	16 ga. satin coat, 1 3/4" deep
<b>Hinge</b>	Full-length piano hinge
<b>Latch</b>	L-Handle operable from both sides. Doors higher than 48" come with 3 handles

<b>Insulation</b>	1" thick AMVIC <i>SilverBoard Ridge Foam Insulation</i>
<b>Gasket</b>	Neoprene gasketing on all 4 sides of door
<b>Finish</b>	Powder coat aluminum finish
<b>Options (at extra cost)</b>	<ul style="list-style-type: none"> <li>Stainless steel #304 and #316 (#4 satin finish)</li> <li>Extra latches</li> <li>Custom sizes available</li> </ul>

The WB-WTD Walk Through Access Door is an insulated walk through door. It provides easy access to interior duct work and air handling equipment. It is constructed with galvanized steel to ensure durability. It comes complete with neoprene gasketing, insulation, full length piano hinge and a T-Handle locking latch that is operable from both sides.

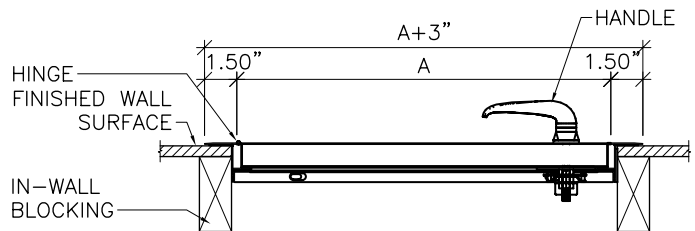

Model No.	A x B Door Size	Hinge	Latch	Shipping Weight (lbs)
WB-WTD 24x36	24" x 36"	1	2	32
WB-WTD 24x48	24" x 48"	1	2	42
WB-WTD 24x60	24" x 60"	1	3	52
WB-WTD 24x72	24" x 72"	1	3	62

Model No.	A x B Door Size	Hinge	Latch	Shipping Weight (lbs)
WB-WTD 30x36	30" x 36"	1	2	39
WB-WTD 30x48	30" x 48"	1	3	52
WB-WTD 30x60	30" x 60"	1	3	65
WB-WTD 30x72	30" x 72"	1	3	78

Rough wall opening = door size + 1/2"



# WB-MAP PLASTIC MULTI-FUNCTIONAL ACCESS DOOR



<b>Door &amp; Frame</b>	High impact ABS plastic with UV stabilizers. Pivot hinged door panel with removable feature for maximum access.
<b>Lock</b>	Door is locked to return frame with snap friction catch
<b>Finish</b>	White textured finish

<b>Installation</b>	Adhesive caulking recommended
<b>Packaging</b>	Individually wrapped. Sold in cases.

The WB-MAP Plastic Multi-Functional Access Door is an economical choice that allows easy access to plumbing, electrical wiring and other utility applications behind walls and ceilings. The door is constructed from high impact ABS plastic and has a textured finish to allow for painting on site if required.

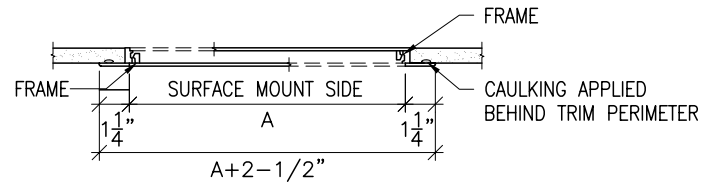

Model No.	Actual Door Size	Frame to Outer Flange	Shipping Weight Per Case (lbs)
WB-MAP 4x6	3 3/4" x 5 3/4"	5" x 7"	3
WB-MAP 6x9	5 3/4" x 8 3/4"	7 3/4" x 10 3/4"	6
WB-MAP 8x8	7 3/4" x 7 3/4"	9 3/4" x 9 3/4"	7
WB-MAP 12x12	11 1/2" x 11 1/2"	14" x 14"	13

Model No.	Actual Door Size	Frame to Outer Flange	Shipping Weight Per Case (lbs)
WB-MAP 14x14	13 3/4" x 13 3/4"	16" x 16"	18
WB-MAP 14X29	14" x 29"	16" x 31"	17
WB-MAP 18x18	18" x 18"	20.5" x 20.5"	13
WB-MAP 22x22	21 3/4" x 21 3/4"	24 3/4" x 24 3/4"	23

# WB-GYP GYPSUM PANEL ACCESS DOOR

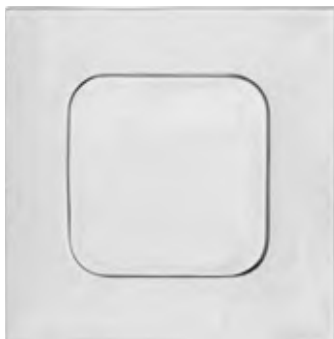

<b>Door &amp; Trim</b>	Glass Fiber Reinforced Gypsum/Cement
<b>Return Frame</b>	Glass Fiber Reinforced Gypsum/Cement
<b>Finish</b>	Unpainted Natural Grey Gypsum

<b>Options</b> (at extra cost)	<ul style="list-style-type: none"> <li>• Neoprene Gasket</li> <li>• Slotted Cam Latch</li> <li>• Keyed Cam Lock</li> <li>• Concealed Hinge Design</li> <li>• Custom Sizes Available</li> </ul>
-----------------------------------	--

The WB-GYP Gypsum Panel Access Door is a state-of-the-art lightweight gypsum panel manufactured from inorganic material and 70% post-consumer recycled glass, using a patented composition. It is designed to blend seamlessly into walls and ceilings. Lightweight and easily textured, the panels can be used in both new or retrofit construction across unlimited applications. It is available in a pop-out or concealed hinged design with square or radius corners. It is moisture resistant with zero mold and fungus growth.

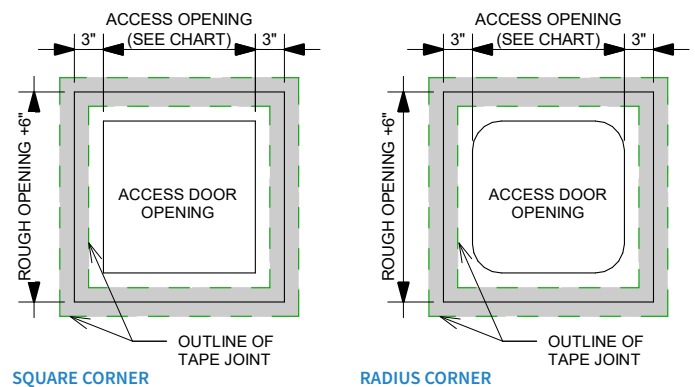

Model No.	A x B Door Size	Shipping Weight (lbs)
WB-GYP 9x9	9" x 9"	5.6
WB-GYP 12x12	12" x 12"	7.6
WB-GYP 16x16	16" x 16"	10.7
WB-GYP 18x18	18" x 18"	18.2
WB-GYP 24x24	24" x 24"	24.9

Rough wall opening = door size + 6"

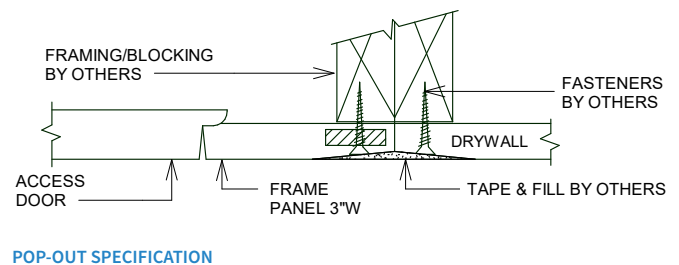

## WB-NTG TRIMLESS GYPSUM ACCESS DOOR



<b>Door and Trim</b>	.080 aluminum extrusion with 5/8" drywall inserted into door panel and brush gasket
<b>Frame</b>	.080 aluminum extrusion (1/2" & 5/8" available)

<b>Hinge</b>	Pivot Type - allows for door removal
<b>Latch</b>	Push to open
<b>Finish</b>	Mill Finish

The WB-NTG Trimless Gypsum Access Door is a high quality access door designed to be as invisible as possible while maintaining an architecturally pleasing appearance. The door is supplied with moisture resistant 5/8" drywall and recessed to allow for finishing of wall or ceiling surface. A safety chain is installed on the door and frame. Brush gasket minimizes debris and air infiltration.

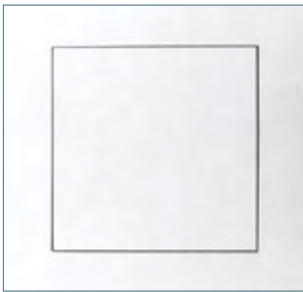
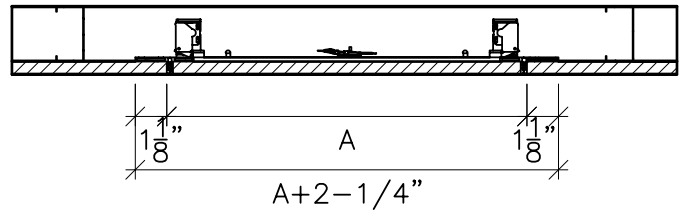

Ceiling view

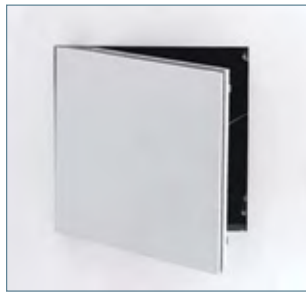

Model No.	Frame Size (w x h)	Weight (lbs) w/o gypsum
WB-NTG 8x8	8" x 8"	1
WB-NTG 12x12	12" x 12"	2
WB-NTG 16x16	16" x 16"	5
WB-NTG 18x18	18" x 18"	6
WB-NTG 20x20	20" x 20"	8
WB-NTG 24x24	24" x 24"	12
WB-NTG 36x36	36" x 36"	18

\* Allow 1/2" around frame for installation

## ACCESS DOOR WARRANTY

The Williams Brothers Corporation (the "Corporation") warrants its metal access doors to be free from defects in material and workmanship for a period of one (1) year from the date of purchase (the "Warranty Period"). During the **Warranty Period**, any such defects will, at the **Corporation's option**, be either repaired or the defective metal access door replaced. This warranty does not cover defects resulting from modifications, alterations, misuse, **accident** or **abnormal condition of operation**, exposure to corrosive conditions or improper installation or maintenance. All implied warranties, including, but not limited to warranties of fitness for purpose and merchantability, are limited to the period as stated above. **The Corporation shall not be liable for any special, indirect, incidental or consequential damages or losses, including loss of profits. This warranty will be the buyer's sole and exclusive remedy and the Corporation** neither assumes nor authorizes any representative or other person to assume for it any obligation or liability other than as expressly set forth herein. **Since some countries or states do not allow limitation of the term of an implied warranty, or exclusion or limitation of incidental or consequential damages, the limitations and exclusions of this warranty may not apply to every buyer. If any provision of this warranty is held invalid or unenforceable by a court of competent jurisdiction, such holding will not affect the validity or enforceability of any other provision.**



**WB 500**  
MEDIUM  
PADDLE LATCH



**WB 501**  
SMALL  
PADDLE LATCH



**WB 502**  
KEY LATCH FOR FR STANDARD  
AND FR BASIC DOOR



**WB 503**  
KNURL KNOB FOR FR STANDARD  
AND FR BASIC DOOR



**WB 504**  
STANDARD CYLINDER LOCK  
(151 KEYCODE)



**WB 505**  
MEDIUM BARREL  
CYLINDER LOCK



**WB 506**  
TAMPER PROOF PINNED TORX  
AND SNAKE EYE SCREWS



**WB 507**  
E SERIES MORTISE BODY  
WITH CHANGEABLE CORE



**WB 508**  
MORTISE  
CYLINDER CORE



**WB 509**  
HEAVY DUTY  
DETENTION LOCK



**WB 510**  
T TYPE  
CABINET HANDLE



**WB 511**  
L TYPE CABINET HANDLE  
(151 KEYCODE)



**WB 512**  
ULTRA KEY LATCH  
(151 KEYCODE)



THE WILLIAMS  
**BROTHERS**  
CORPORATION

**The Williams Brothers Corporation**

777 Tapscott Road,  
Scarborough, Ontario,  
Canada M1X 1A2

Phone 416.299.7767  
1.888.575.1132  
Fax 416.299.8039

info@williams-brothers.com  
**williams-brothers.com**

Dealer Name:

Specify the following Williams Brothers Corporation products when quality counts:

- Rated & Non-Rated Fire Extinguisher Cabinets • Fire Hose Cabinets
- Valve Cabinets • Flammable Safety Storage Cabinets