



WB-NTG TRIMLESS GYPSUM ACCESS DOOR

The WB-NTG Trimless Gypsum Access Door is a high quality access door designed to be as invisible as possible while maintaining an architecturally pleasing appearance. The door is supplied with moisture resistant 5/8" drywall and recessed to allow for finishing of wall or ceiling surface. A safety chain is installed on the door and frame. Brush gasket minimizes debris and air infiltration.

FEATURES

| | |
|----------------------|---|
| Door and Trim | .080 aluminum extrusion with 5/8" drywall inserted into door panel and brush gasket |
| Frame | .080 aluminum extrusion (1/2" & 5/8" available) |
| Hinge | Pivot Type - allows for door removal |
| Latch | Push to open |
| Finish | Mill finish |

| Model No. | Frame Size (w x h) | Weight (lbs) w/o gypsum |
|--------------|--------------------|-------------------------|
| WB-NTG 8x8 | 8" x 8" | 1 |
| WB-NTG 12x12 | 12" x 12" | 2 |
| WB-NTG 16x16 | 16" x 16" | 5 |
| WB-NTG 18x18 | 18" x 18" | 6 |
| WB-NTG 20x20 | 20" x 20" | 8 |
| WB-NTG 24x24 | 24" x 24" | 12 |
| WB-NTG 36x36 | 36" x 36" | 18 |

Allow 1/2" around frame for installation

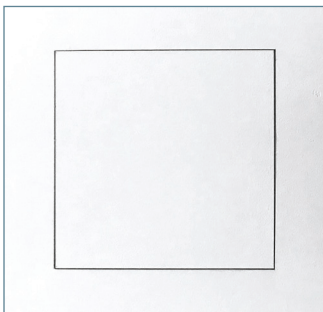

Ceiling view

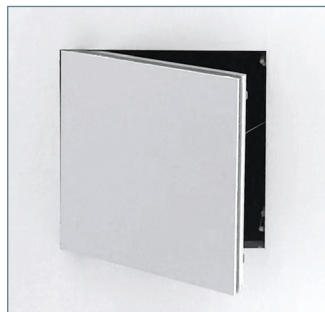

WB-NTG

DIMENSIONS

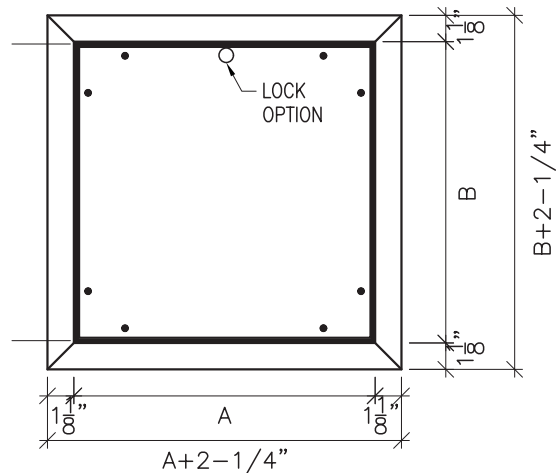

Elevation

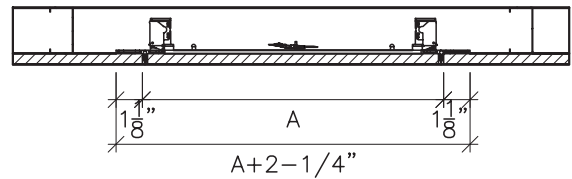

Section Detail