



WB-UAD UTILITY ACCESS DOOR

The WB-UAD Utility Access Door is an innovative, cost-effective access door. This door is laser cut from 16-gauge cold rolled steel and of uniweld construction that allows for an aesthetically pleasing appearance and square fit for wall and ceiling applications. This door features a spring-loaded pin hinge that allows the door panel to be removed.

FEATURES

| | |
|-----------------------------------|----------------------------------------------------------------------------------------------------------------------------------------------------------------------------------------------------------------------------------------------------------------------------------------------|
| Door and Trim | 16 ga. cold rolled steel, trim 1 1/2" wide |
| Return Frame | 16 ga. cold rolled steel, depth of 1 3/4" |
| Hinge | Spring pin hinge up to 24" x 24" Piano hinge on doors larger than 24" x 24" |
| Latch | Flush, stainless steel cam operated with screwdriver. Latches are positioned opposite hinge as well as top and bottom on larger sizes. |
| Finish | White powder coat paintable finish |
| Options (at extra cost) | <ul style="list-style-type: none"> • Tamper Proof Cams, Hex, Torx Pin screw assembly • Key cylinder lock with key (code 151) • Mortise Lock Preparation • Stainless Steel #304 or #316 (#4 satin finish) • Galvanized/Zinc Coating Finish |

| Model No. | A x B Door Size | Cam Latch | Shipping Weight (lbs) Steel/Stainless |
|--------------|-----------------|-----------|---------------------------------------|
| WB-UAD 6x6 | 6" x 6" | 1 | 1 |
| WB-UAD 8x8 | 8" x 8" | 1 | 3 |
| WB-UAD 8x12 | 8" x 12" | 1 | 4.1 |
| WB-UAD 10x10 | 10" x 10" | 1 | 4.1 |
| WB-UAD 12x12 | 12" x 12" | 1 | 5 |
| WB-UAD 14x14 | 14" x 14" | 3 | 6 |
| WB-UAD 16x16 | 16" x 16" | 3 | 6.8 |
| WB-UAD 18x18 | 18" x 18" | 3 | 10 |
| WB-UAD 18x24 | 18" x 24" | 3 | 14.1 |
| WB-UAD 20x20 | 20" x 20" | 3 | 11 |
| WB-UAD 22x22 | 22" x 22" | 4 | 14.4 |
| WB-UAD 22x30 | 22" x 30" | 4 | 16.1 |
| WB-UAD 22x36 | 22" x 36" | 5 | 17.1 |
| WB-UAD 24x24 | 24" x 24" | 4 | 15 |
| WB-UAD 24x30 | 24" x 30" | 4 | 19.5 |
| WB-UAD 24x36 | 24" x 36" | 5 | 22.5 |
| WB-UAD 24x48 | 24" x 48" | 6 | 30 |
| WB-UAD 30x30 | 30" x 30" | 6 | 24 |
| WB-UAD 36x36 | 36" x 36" | 9 | 34 |

Rough wall opening = door size + 1/8"



WB-UAD

DIMENSIONS

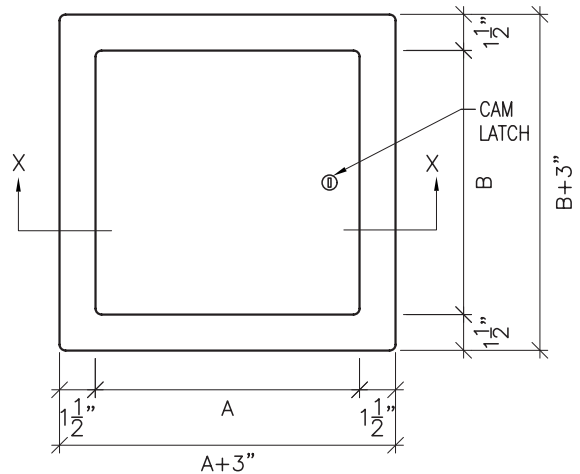

Elevation

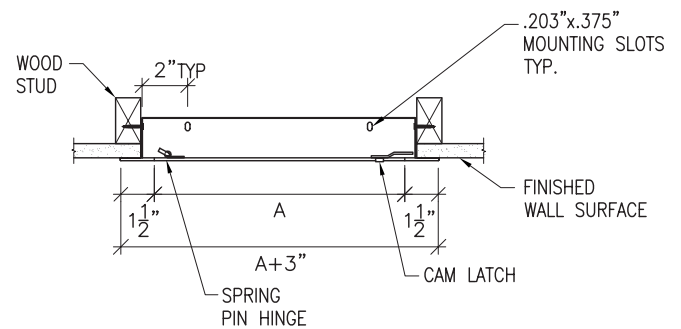

Section Detail