

CM-1101 OUTDOOR WEATHERPROOF HOSE STORAGE CABINET

The CM-1101 Outdoor Weatherproof Hose Storage Cabinet: designed for industrial outdoor applications and the storage of fire hoses and equipment. Fabricated from 16-gauge galvanized steel and finished with Super Durable UV resilient polyester powder coat red paint with a high gloss finish. Available in four different mounting options. This cabinet comes complete with an adjustable shelf (1), louvers for ventilation, and 2" sloped roof that is reinforced with a rain trough.

FEATURES

Cabinet Material	16 ga. galvanized steel
Hinge	Stainless steel piano hinges
Latch	Chrome plated zinc handle with 2-point catch
Shelf	(1) 13" Deep Adjustable Shelf
Finish	Super Durable Polyester Powder Coat Paint (Gloss Finish) Optional: Safety Yellow & White
Features	<ul style="list-style-type: none"> • Rain trough over doors • Doors overlap tub at hinge side • Louvers on both sides of cabinet
Options	<ul style="list-style-type: none"> • Additional shelves • FIRE HOSE - 4" h Die cut vinyl white lettering • Stainless Steel Construction (316) • Aluminum Construction • Wrench & Axe brackets • Padlock hasp

Model No.	Size (w x h x d)	Description
Type A	57" (145 cm) x 48" (122 cm) x 15" (38 cm)	Free Standing
Type B		Wall mounted (with rear lugs top & bottom)
Type C		Concrete base mounted (with grouting lugs at bottom)
Type D		Support Mounted - as shown with 24" legs (Steel fabricated legs available 12", 18", 24", 36")



CM-1101 - TYPE D
(24" LEGS SHOWN)

DIMENSIONS

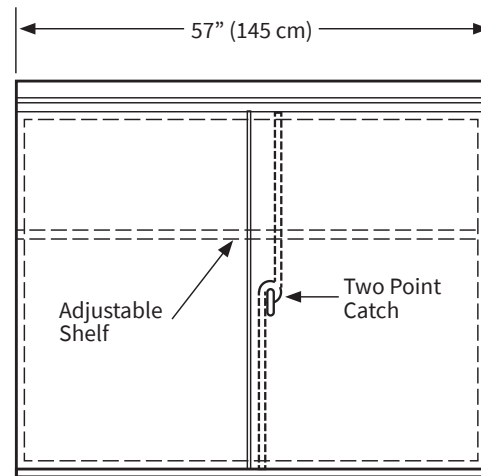

Elevation

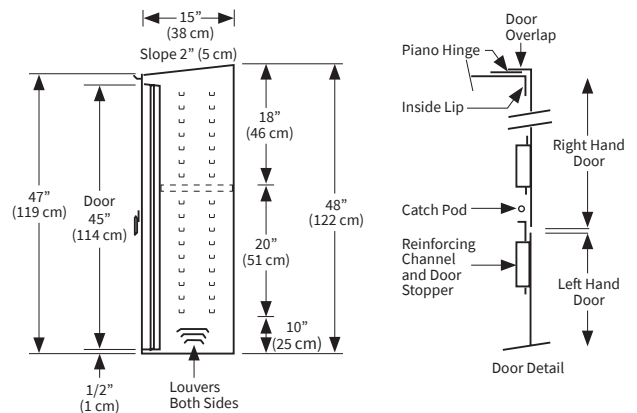

Section Detail