



## WB-AT ACOUSTICAL TILE ACCESS DOOR

The WB-AT Acoustical Tile Access Door is a ceiling precision door that provides a virtually concealed installation, keeping acoustical surfaces intact while contributing to sound control and better appearance. Door is recessed to accept up to 5/8" thick acoustical tile. Each door comes complete with grommets.

### FEATURES

|                                   |  |
|-----------------------------------|--|
| <b>Door</b>                       | 16 ga. cold rolled steel. Door is recessed to accept up to 5/8" acoustical tile.   |
| <b>Box Return Frame</b>           | 16 ga. cold rolled steel   |
| <b>Hinge</b>                      | Continuous piano hinge opens 180 degrees, will be placed on long side of door unless otherwise requested.                          |
| <b>Latches</b>                    | Flush, stainless steel cam operated with screwdriver. Latches positioned opposite hinge as well as top and bottom on larger sizes. |
| <b>Finish</b>                     | White powder coat paintable finish   |
| <b>Options</b><br>(at extra cost) | Medium barrel cylinder lock  |

| Model No.   | A x B<br>Door Size | Hinges | Cam Latch | Shipping<br>Weight (lbs) |
|-------------|--------------------|--------|-----------|--------------------------|
| WB-AT 12x12 | 12" x 12"          | 1      | 1         | 8                        |
| WB-AT 12x24 | 12" x 24"          | 1      | 2         | 13                       |
| WB-AT 18x18 | 18" x 18"          | 1      | 3         | 15                       |
| WB-AT 24x24 | 24" x 24"          | 1      | 3         | 25                       |
| WB-AT 24x36 | 24" x 36"          | 1      | 5         | 33                       |

Rough ceiling opening = door size + 1/4"



WB-AT

### DIMENSIONS

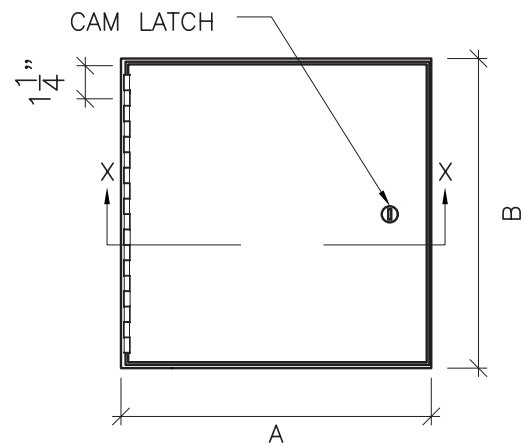

Elevation

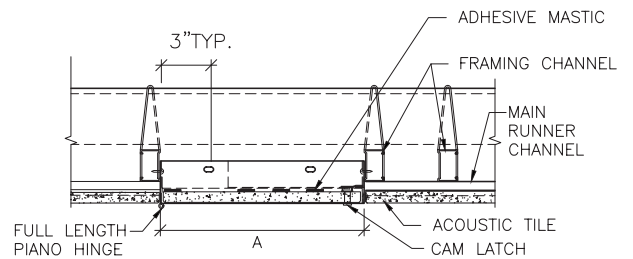

Section Detail